

Parker Hyferset

Hydraulic Presetting Tool
Bulletin 4393-B1



ENGINEERING YOUR SUCCESS.

Table of Contents

Introduction..... 1

Set-Up Instructions 2

Tube-End Preparation..... 3

Presetting Metric Fittings (EO/EO-2)..... 4

Presetting Metric Fittings (Ferulok)..... 8

Maintenance and Troubleshooting..... 11

Parts Schematic 15

Offer of Sale 17

 **WARNING**

FAILURE OR IMPROPER SELECTION OR IMPROPER USE OF THE PRODUCTS AND/OR SYSTEMS DESCRIBED HEREIN OR RELATED ITEMS CAN CAUSE DEATH, PERSONAL INJURY AND PROPERTY DAMAGE.

This document and other information from Parker Hannifin Corporation, its subsidiaries and authorized distributors provide product and/or system options for further investigation by users having technical expertise. It is important that you analyze all aspects of your application and review the information concerning the product or system in the current product catalog. Due to the variety of operating conditions and applications for these products or systems, the user, through its own analysis and testing, is solely responsible for making the final selection of the products and systems and assuring that all performance, safety and warning requirements of the application are met.

The products described herein, including without limitation, product features, specifications, designs, availability and pricing, are subject to change by Parker Hannifin Corporation and its subsidiaries at any time without notice.

Offer of Sale

The items described in this document are hereby offered for sale by Parker Hannifin Corporation, its subsidiaries or its authorized distributors. This offer and its acceptance are governed by the provisions stated in the "Offer of Sale".

© Copyright 2016, Parker Hannifin Corporation. All rights reserved.



Hyferset Portable Presetting Tool



Easy to Operate

The Hyferset is an efficient, dependable device for presetting Ferulok and EO/EO-2 fittings. The tool is capable of presetting on tubing of steel, stainless steel and Monel material. Complete the task with ease by selecting the correct components and using a hydraulic hand or electric pump.



Portable

The lightweight Hyferset (35 lb. base unit) can be easily moved around the workplace. A wooden carrying case is available to aid portability.

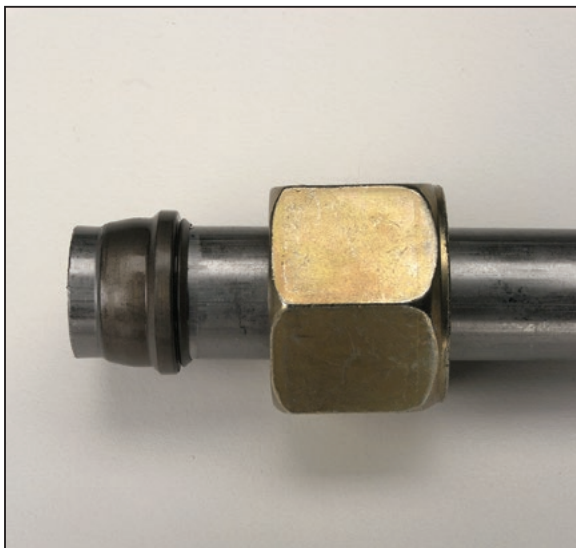

Presetting

The Hyferset is capable of presetting Ferulok ferrules for tube sizes 1/4" through 2" and EO/EO-2 cutting rings and functional nuts for tube sizes 6mm through 28mm.



Hydraulic Pump

The Hyferset can be used with an electric-hydraulic or hand-hydraulic pump to give the user choices of power.

- Step 1 Hyferset Adapter**
 Install the straight adapter (part number 6 FLO-S) into the NPTF pipe thread port in the rear of the Hyferset with a pipe sealant. **Note:** If you are **NOT** installing the pressure gauge, proceed to Step 4.

- Step 2 Swivel Tee**
 Install the swivel end of the “T” fitting (part number 6 R6LO-S) on the Hyferset adapter. Make sure the branch end of the “T” is oriented in the upward direction.

- Step 3 Pressure Gauge**
 Install the conversion adapter (part number 6 G6L-S) to the pressure gauge (part number 900044). Install the adapter/gauge assembly to branch end of the “T” fitting.

- Step 4 Hose / Pump Assembly**
 Install the male pipe thread end of the hose assembly (part number 900004) to the female pipe thread port of either the electric-hydraulic or hand-hydraulic pump.

- Step 5 Hose / Hyferset Assembly**
 If you are using a pressure gauge, install the swivel end of the hose to the remaining end of the “T” fitting. If you are **NOT** using a pressure gauge, install the hose end to the male end of 6 FLO-S.

- Step 6 Check for Leaks**
 Operate the hydraulic pump and check for leaks at the connections.

- Note:** If you order the Hyferset Kit, please note the pressure gauge is not included.

Caution: A pressure gauge is required with metric presets (EO/EO-2) and is optional on inch presets with positive stop dies.

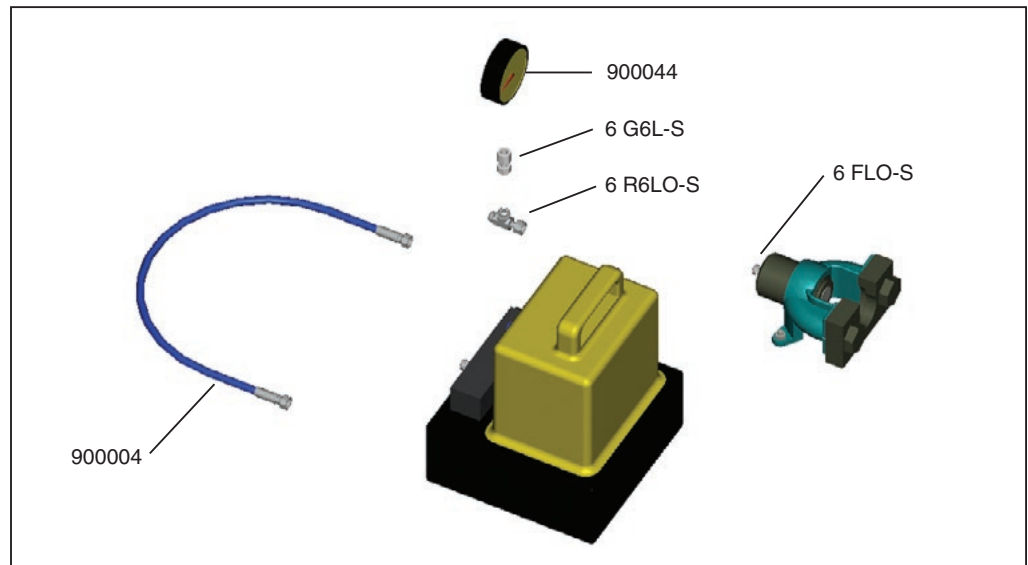

Fig. 1 — Set-up

For Your Safety

When using this machine on a bench, be sure that the hose assembly does not extend over the edge of the bench where it can be struck by plant equipment.

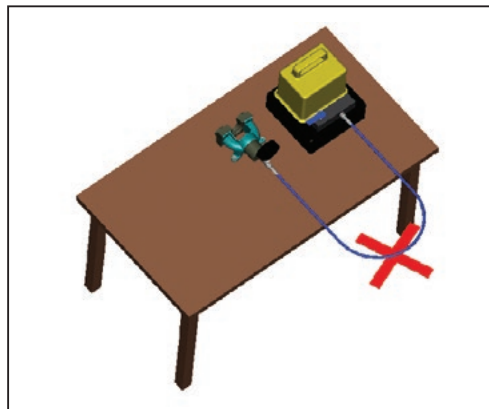

Fig. 2 — Incorrect Method

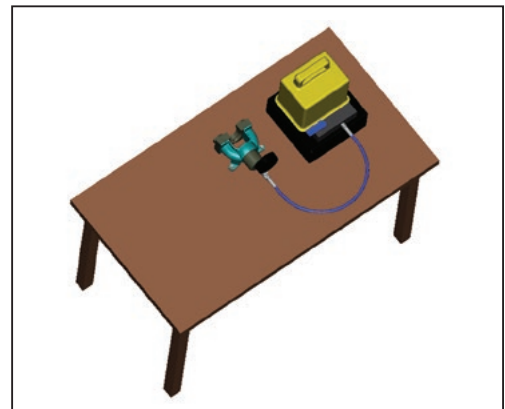

Fig. 3 — Correct Method

Tube-End Preparation

Tube-end preparation is one of the most critical processes in obtaining an optimum seal of a preset tube end connection. Regardless of the tube material, similar guidelines for tube cut-off, deburring and cleanliness can help assure the tube-to-fitting connection remains leak free.

Tube Cutting

- It is critical that the tube be cut squarely within $\pm 1^\circ$ in order to assure the proper tube-to-fitting connection. If the tube is not cut squarely, it will result in the tube not resting properly in fitting body during presetting.
- When cutting tube in preparation for presetting, a saw which uses a toothed blade is recommended. This type of tool will assure that the tube end is not hardened from excessive heat or working of material.

Recommended:

Hacksaw, Low-Speed Circular Saw

Not Recommended:

Tube Cutter, Abrasive Saw

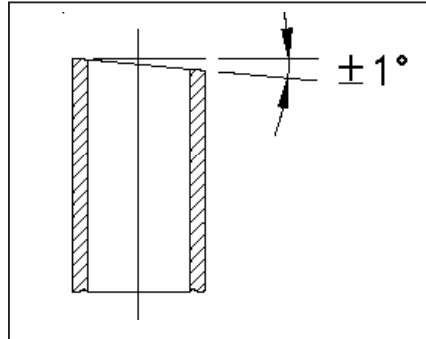

Fig. 4 — Tube Cut Angle

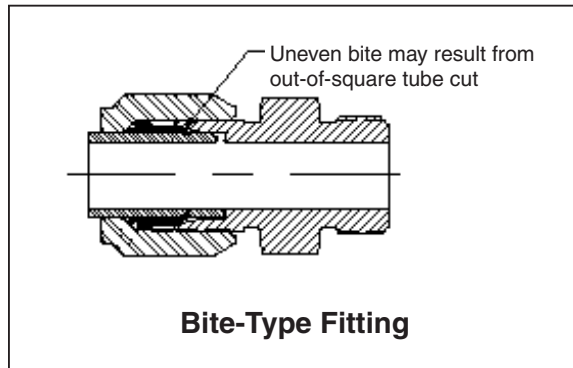

Fig. 5 — Cutaway Bite-Type Fitting

Tube Deburring

- Deburring the inside and outside diameter of the tube end is necessary to assure the tube fits properly inside the ferrule and fitting body. Proper deburring of the tube end is also necessary to help the tubing fit properly in the body die.

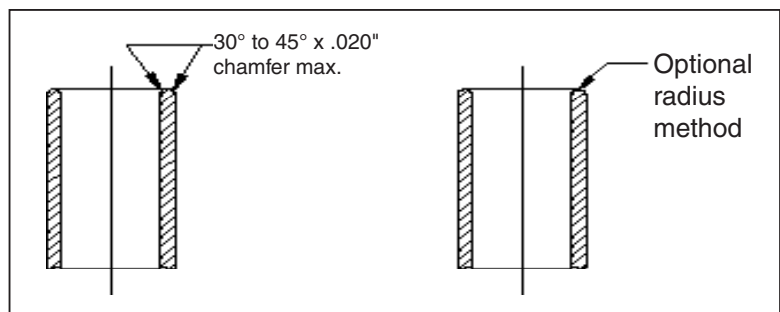

Fig. 6 — Tube Deburring

Operating Information for Presetting Metric Fittings (EO/EO-2)

Components Required

Sizes 6mm through 28mm

Description	Part Number
Nut Die	See Table 1
Body Die	See Table 1



Fig. 7 — Nut Die



Fig. 8 — Body Die

Step 1 Select Tooling

Select the necessary tooling from Table 1 based on the size of the tube/fitting to be preset.

Tube O.D. Size (mm)	Part No.		
	Nut Die	Body Die L-Series	Body Die S-Series
6	910291-6 mm	910290-6L	910289-6S
8	910291-8 mm	910290-8L	910289-8S
10	910291-10 mm	910290-10L	910289-10S
12	910291-12 mm	910290-12L	910289-12S
14	910291-14 mm		910289-14S
15	910291-15 mm	910290-15L	
16	910291-16 mm		910289-16S
18	910291-18 mm	910290-18L	
20	910291-20 mm		910289-20S
22	910291-22 mm	910290-22L	
25	910291-25 mm		910289-25S
28	910291-28 mm	910290-28L	

Table 1 — Body Dies and Nut Dies for EO and EO-2 Fittings

Hyferset Presetting Pressures for Metric Fittings (EO/EO-2)

Pre-Setting Pressures (psi) for Steel EO Fittings ^{1,2}					
Tube Size (mm)	Wall Thickness (mm)				
	1.0	1.5	2.0	2.5	3.0
6-L	650	650			
6-S	650	650			
8-L	900	900			
8-S	900	900			
10-L	1,350	1,350	1,550		
10-S	1,350	1,350	1,550		
12-L	1,750	1,750	1,750	1,750	
12-S	1,750	1,750	1,750	1,750	
14-S		2,000	2,000	2,200	2,200
15-L	1,800	1,800			
16-S		2,200	1,450	1,450	
18-L	2,000	2,000	2,000		
20-S			3,300	3,500	
22-L		3,100	3,100		
25-S				4,000	4,000
28-L		3,500	3,500		

Table 2 — Presetting Pressures for Steel EO Fittings^{1,2}

Pre-Setting Pressures (psi) for Stainless Steel EO Fittings ^{1,2}					
Tube Size (mm)	Wall Thickness (mm)				
	1.0	1.5	2.0	2.5	3.0
6-L					
6-S					
8-L					
8-S					
10-L					
10-S					
12-L		1,900			
12-S		1,900			
14-S					
15-L		2,200			
16-S			2,600		
18-L		2,500			
20-S			4,000		
22-L					
25-S			4,300	4,500	4,500
28-L			4,300		

Table 3 — Presetting Pressures for Stainless Steel EO Fittings^{1,2}

Hyferset Pre-Setting Pressures (psi) for EO-2 Fittings ^{1,2}		
Size	Series	Any wall
6	L	1,150
6	S	1,150
8	L	1,450
8	S	1,450
10	L	2,450
10	S	2,450
12	L	2,800
12	S	2,800
14	S	3,500
15	L	2,800
16	S	3,900
18	L	3,200
20	S	5,600
22	L	4,950
25	S	6,400
28	L	5,600

Table 4 — Presetting Pressures for Steel and Stainless Steel EO-2 Fittings^{1,2}

- CAUTION:** EO and EO-2 presetting dies are not positive stop style. Presetting must be done using pressures given in Tables 2 through 4.
- The values provided in Table 2 through 4 are provided as a guide only and normally will produce a satisfactory bite when using the Parker Hyferset.

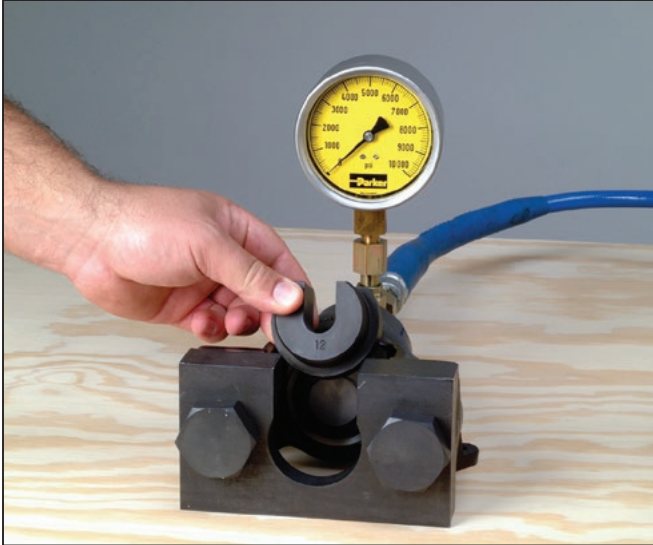

Step 2 Install the Nut Die
 Insert the nut die in the back-up plate opening from the inside so that the nut support shoulder seats squarely in the counterbore of the back-up plate. The spring loaded ball plunger will secure the nut support in the proper position.



Step 3 Install the Nut and Progressive Ring onto the Tube
 Slide the nut and progressive ring onto the tube. For EO, the straight pilot section (bite edge) points toward the end of the tube on which it is to be preset, and the raised portion of the progressive ring points toward the nut. For EO-2, slide the functional nut assembly onto the tube with the threaded end of the nut facing the end of the tube to be preset.



Step 4 Lubricate the Progressive Ring (EO Only)
 Lubricate the leading outer (bite) edge of the ferrule with lubricant, comparable to the viscosity of STP®. This reduces wear on the die and lowers friction, ensuring that all the force is available to preset the progressive ring.



Step 5 Install the Body Die
 Lubricate the inside of the body die with lubricant (EO only), comparable to the viscosity of STP®. Install the body die over the tube end until the tube bottoms on the die shoulder. Push the nut and progressive ring forward to place the parts in correct position for presetting. The body die will enter the bore of the nut, and the parts will be in the correct position for presetting.

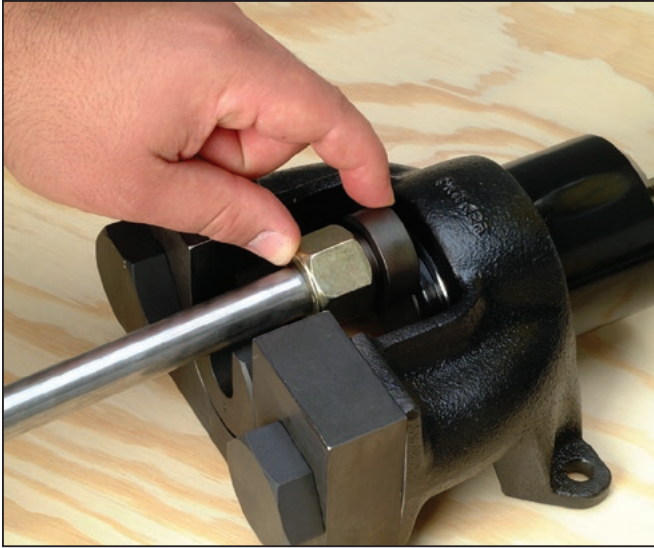

Step 6 Position the Assembly for Presetting
Place the tube within the slot in the nut support.



Step 7 Preset the Ferrule
Determine the required preset pressure based on the tube size from the table on page 4. Apply hydraulic pressure with a hand or electric pump to advance the piston of the Hyferset. Continue the operation until the predetermined pressure is reached. De-energize the hydraulic power supply or release the valve on the hand pump. The Hyferset piston will retract.



Step 8 Remove the Tube
Lift out the tube with preset progressive ring and inspect it according to the procedures shown on the following page.

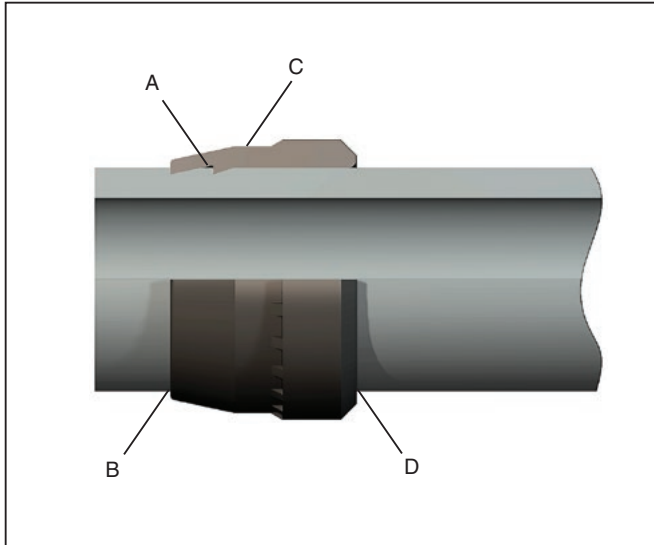

Fig. 9 — EO Bite Preset Inspection

EO Bite Preset Inspection

The following detailed inspection must be followed after the ferrule has been preset to the tube.

1. A ridge of metal (A) should be raised above the tube surface to a height of at least 50% of the thickness of the progressive ring/cutting ring's leading edge, all the way around the tube.
2. The leading edge of the progressive ring/cutting ring should be coined flat (B).
3. There must be a bow in the pilot section of the ferrule (C).
4. The tail or back end of the progressive ring/cutting ring should be snug against the tube (D).

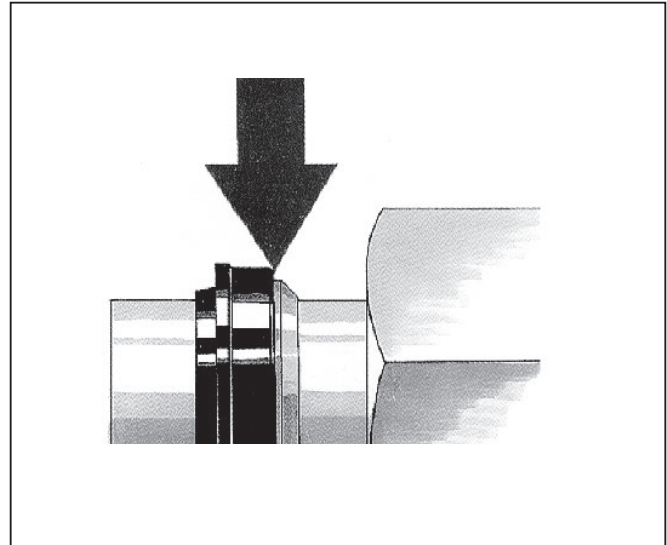

Fig. 10 — EO-2 Bite Preset Inspection

EO-2 Bite Preset Inspection

The following inspection must be followed after the ferrule (DOS) has been preset to the tube.

1. Push back the nut past the seal ring (DOZ) and ferrule (DOS). Check that the gap between the seal ring (DOZ) and the ferrule (DOS) is almost closed or fully closed. A slight gap (up to 0.2mm) due to spring back is acceptable. The gap will be uniform around the tube if not preset correctly.

Operating Information for Presetting Inch Fittings (Ferulok)

Components Required

Sizes 1/4" through 2"

Description	Part Number
Nut Die	See Table 5
Body Die	See Table 5



Fig. 11 — Nut Die



Fig. 12 — Body Die

Step 1 Select Tooling

Select the necessary tooling from Table 5 based on the size of the tube/fitting to be preset.

Size	Tube O.D. (in.)	Nut Die Part No.	Body Die Part No.
4	1/4	680370-4	720105-4
6	3/8	680370-6	720105-6
8	1/2	680370-8	720105-8
10	5/8	680370-10	720105-10
12	3/4	680370-12	720105-12
14	7/8	680370-14	720105-14
16	1	680370-16	720105-16
20	1 1/4	680370-20	720105-20
24	1 1/2	680370-24	720105-24
32	2	680370-32	720105-32

Table 5 — Body Dies and Nut Dies for Ferulok

Hyferset Presetting Pressures for Inch Fittings (Ferulok)^{1), 2), 3)}

Tube Size	Wall Thickness — Steel							Wall Thickness — Stainless Steel						
	0.035	0.049	0.065	0.083	0.095	0.109	0.120	0.035	0.049	0.065	0.083	0.095	0.109	0.120
4	800	900	1,400	1,800	1,800	1,800		900	1,000	1,500	2,000	2,000	2,000	
6	900	1,400	800	2,000	2,000	2,000	2,200	1,000	1,500	2,000	2,000	2,000	2,000	2,500
8		1,600	2,000	2,500	2,700	3,000	3,200		1,800	2,200	3,000	3,000	3,500	3,500
10			2,200	2,700	3,000	3,500	3,500			2,500	3,000	3,500	4,000	4,000
12			2,700	3,000	3,500	3,500	4,000			3,000	3,500	4,000	4,000	4,500
14			3,000	3,500	3,500	4,000	4,500			3,000	4,000	4,000	4,500	5,000
16				3,500	4,000	4,500	5,000				4,500	4,500	5,000	5,000
18				4,000	4,500	4,500	5,000				4,500	5,000	5,000	5,500
20					4,500	5,000	5,500					5,000	6,000	6,000
24					5,500	6,000	7,000					6,500	7,000	7,000
28					7,000	7,500	8,000					7,500	8,000	8,500
32					8,500	9,000	10,000					9,500	10,000	10,000

Table 6 — Presetting Pressures for Steel and Stainless Steel Ferulok Fittings^{1), 2), 3)}

1. Ferulok presetting dies are positive stop dies. Use of the pressures shown above is optional.
2. The values provided in the table are provided as a guide only and normally will produce a satisfactory bite when using the Parker Hyferset.
3. For wall thicknesses greater than those listed, contact the Tube Fittings Division.

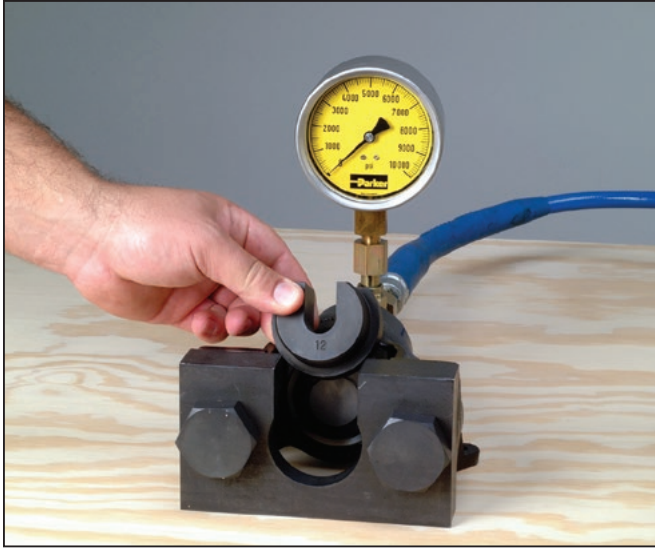

Step 2 Install the Nut Die
Insert the nut die in the back-up plate opening from the inside so that the nut support shoulder seats squarely in the counterbore of the back-up plate. The spring loaded ball plunger will secure the nut support in the proper position.

Step 3 Presetting Pressure (optional for inch sizes)
Based on the tube outside diameter and wall thickness, determine the presetting pressure from Table 6 on the previous page.



Step 4 Assemble the Nut and Ferrule to the Tube
Slide the nut and ferrule onto the tube. The straight pilot section (bite edge) points toward the end of the tube on which it is to be preset, and the raised portion of the ferrule points toward the nut.



Step 5 Lubricate the Ferrule
Lubricate the leading outer (bite) edge of the ferrule with lubricant, comparable to the viscosity of STP®. This reduces wear on the die and lowers friction, ensuring that all the force is available to preset the ferrule.



Step 6 Install the Body Die
Lubricate the inside of the body die with lubricant, comparable to the viscosity of STP®. Install the body die over the tube end until the tube bottoms on the die shoulder. Push the nut and ferrule forward to place the parts in correct position for presetting. The body die will enter the bore of the nut, and the parts will be in the correct position for presetting.

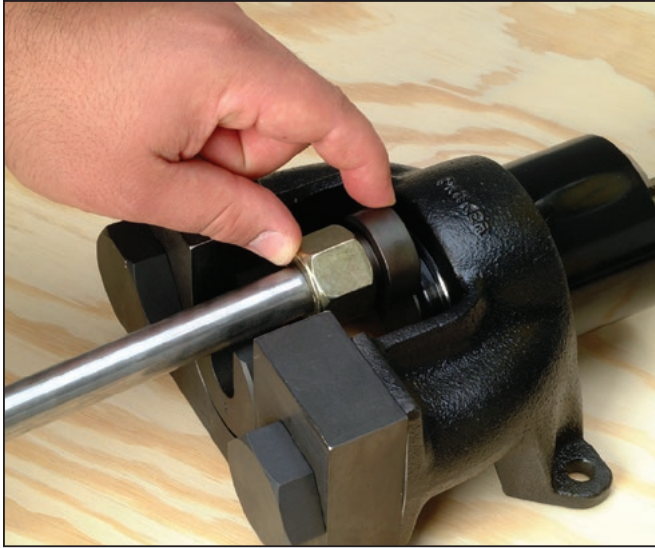

Step 7 Position the Assembly for Presetting
 Place the tube in the slot of the nut support.

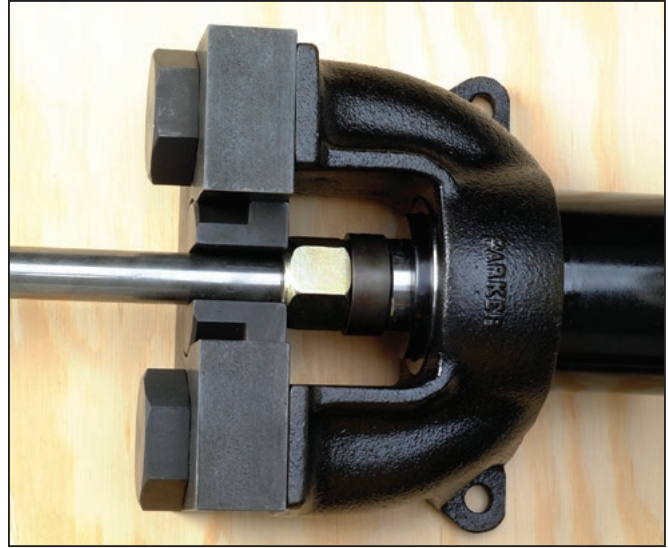

Step 8 Method 1: Using Pressure Gauge
 Apply hydraulic pressure to advance the piston of the Hyferet. Continue the operation until the predetermined pressure is reached. De-energize the hydraulic power supply. The Hyferet piston will retract.

Method 2: Using Positive Stop
 Follow steps 1-7, skipping step 3, then watch the nut make positive contact (bottom out) on the shoulder of the body die. After contact is made, de-energize the hydraulic power supply allowing the Hyferet to retract.



Step 9 Remove the Tube
 Lift out the tube with preset ferrule and inspect it according to the procedures shown to the right.

Ferrule Bite Preset Inspection

The following detailed inspection must be followed after the ferrule has been preset to the tube.

1. A ridge of metal (A) should be raised above the tube surface to a height of at least 50% of the thickness of the ferrule's leading edge, all the way around the tube.
2. The leading edge of the ferrule should be coined flat (B).
3. There must be a bow in the pilot section of the ferrule (C).
4. The tail or back end of the ferrule should be snug against the tube (D).
5. The end of the tube (E) indicates the tube was bottomed in the tool or fitting during presetting.

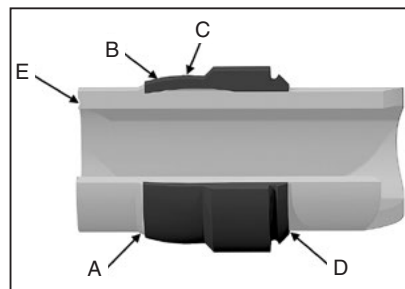

Fig. 13 – Ferrule Bite Preset Inspection

Maintenance of Hyferset Unit and Components

- All moving parts should be kept clean.
- All tooling should be handled carefully to avoid damaging smooth surfaces. Presence of nick, burrs, pieces of dirt or chips may mar the surfaces of the tube.
- Lubrication is a necessity when presetting. A lubricant with a similar viscosity to STP® should be used.

EO Troubleshooting Guide

Problems with bite type hydraulic fittings are most often traced to faulty pre-set/assembly procedure.

Problem / Probable Cause	Remedy
Tube not bottomed	Check for a visible mark on the tube end with EO fitting. (Fig. 14)
Shallow bite	Inspect for turned up ridge of material (collar). A failure to achieve this ridge can be traced either to the nut not being tightened enough or the tube not being bottomed against the stop which allowed the tube to travel forward with the progressive ring. In some instances this assembly may be re-worked. (Fig. 15)
Over-set progressive ring	Too much pressure or more than recommended turns from finger tight were used to pre-set progressive ring, or the nut was severely over-tightened in final assembly. This assembly should be scrapped. (Fig. 16)
Progressive ring cocked on tube	The progressive ring may become cocked on the tube when the tube end is not properly lined up with the body. Generally, this condition is caused by faulty tube bending. All bent tube assemblies should drop into the fitting body prior to make up. This assembly should be scrapped. (Fig. 17)
No bite	If all of the prior checks have been made and the progressive ring still shows no sign of biting the tube, it may be that the tube is too hard. This assembly should be scrapped. (Fig. 18)

Table 7 — EO Fitting Troubleshooting Guide

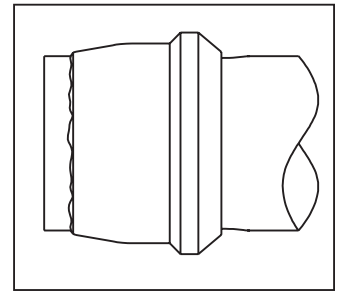

Fig. 14 — Tube not bottomed

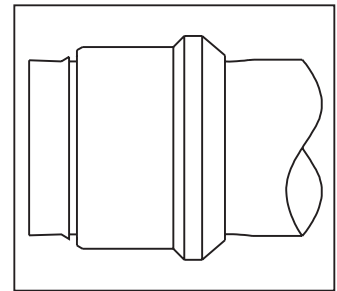

Fig. 15 — Shallow bite

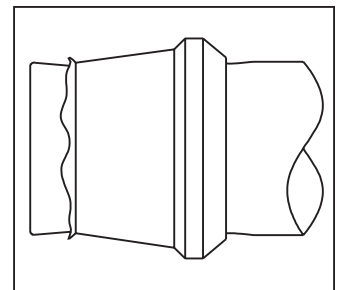

Fig. 16 — Over-set progressive cocked on tube

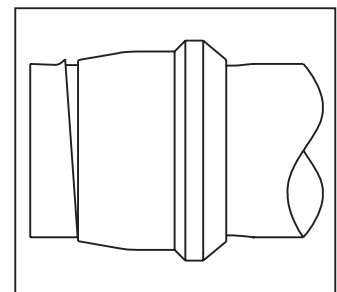

Fig. 17 — Progressive ring ring

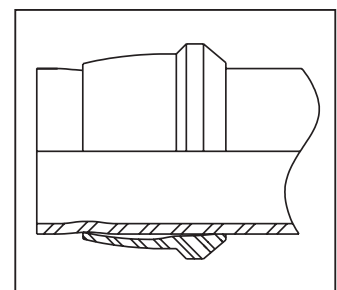

Fig. 18 — No bite

EO-2 Trouble Shooting Guide

Problems with bite type hydraulic fittings are most often traced to faulty pre-set/ assembly procedure.

Problem / Probable Cause	Remedy
Tube not bottomed	The tube end is not in firm contact with the fitting body at assembly. The tubing was not completely inserted into the throat of the fitting body until it bottomed out. Failure to bottom out the tubing against the tube stop of the fitting body during the presetting procedure will allow the tube to travel forward with the functional nut resulting in a shallow bite. This assembly should be scrapped.
Shallow bite	After presetting, inspect to see that the gap between the bite ring and the sealing ring is closed. A failure to achieve a closed gap can be traced to the nut not being tightened enough. This assembly can be reworked by completing the assembly instructions as indicated in the catalog. (Fig. 19)
Damaged seals	Check sealing area for contamination such as chips, zinc particles or other dirt. Also check the inner cone of the fitting body and tubing for damage. Replace DOZ sealing ring if necessary.
Fatigue crack at bite	Ensure proper assembly techniques are utilized. Utilize lubrication and wrench elongation for larger sizes. Check that the gap between the sealing ring and bite ring are closed.
Fatigue crack at rear shoulder of bite ring	Check that the application does not have excessive vibration. Utilize rigid clamping, tension piping or hose assemblies if relative movements are evident.

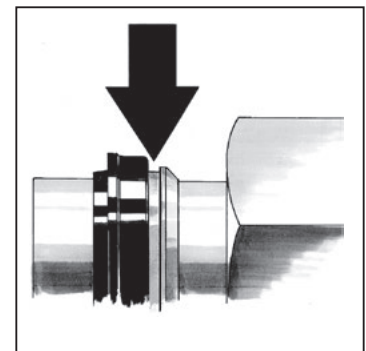

Fig. 19 — Shallow bite

Table 8 — EO-2 Fitting Troubleshooting Guide

Ferulok Trouble Shooting Guide

Problems with bite type hydraulic fittings are most often traced to faulty Ferulset/ assembly procedure.

Problem / Probable Cause	Remedy
Tube not bottomed	Check for the indentation on the tube end or compare the length from the end of the tube to the front end of the ferrule of a known good assembly to that of the assembly in question. This assembly should be scrapped. (Fig. 20)
Shallow bite	Inspect for turned up ridge of material. A failure to achieve this ridge can be traced either to the nut not being tightened enough or the tube not being bottomed against the stop which allowed the tube to travel forward with the ferrule. In some instances this assembly may be re-worked. (Fig. 21)
Over-set ferrule	Too much pressure or more than 1-3/4 turns from finger tight were used to pre-set ferrule, or the nut was severely over-tightened in final assembly. This assembly should be scrapped. (Fig. 22)
Ferrule cocked on tube	The ferrule may become cocked on the tube when the tube end is not properly lined up with the body. Generally, this condition is caused by faulty tube bending. All bent tube assemblies should drop into the fitting body prior to make up. This assembly should be scrapped. (Fig. 23)
No bite	If all of the prior checks have been made and the ferrule still shows no sign of biting the tube, it may be that the tube is too hard. This assembly should be scrapped. (Fig. 24)

Table 9 — Ferulok Fitting Troubleshooting Guide

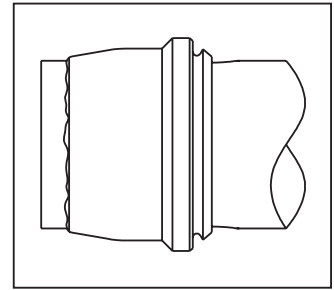

Fig. 20 — Tube not bottomed

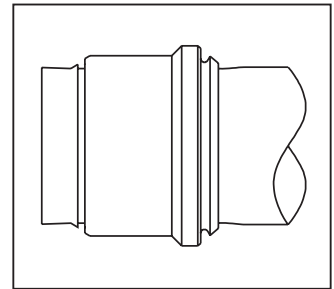

Fig. 21 — Shallow bite

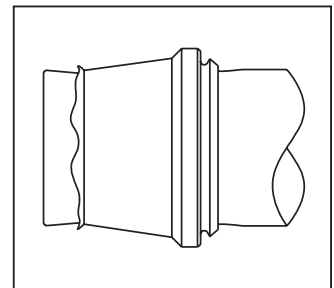

Fig. 22 — Over-set ferrule

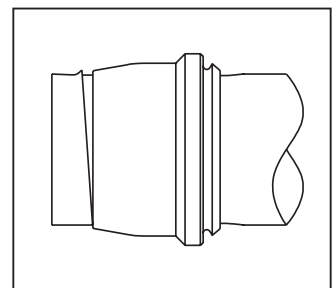

Fig. 23 — Ferrule cocked on tube

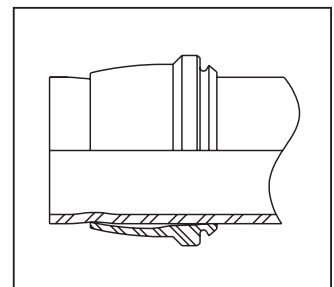

Fig. 24 — No bite

Hyferset Machine and Components Troubleshooting Guide

Problems with bite type hydraulic fittings are most often traced to faulty Ferulset/assembly procedure.

Problem / Probable Cause	Remedy
Cylinder does not advance	<ul style="list-style-type: none"> • Check the pump to see if the fluid is being provided. • Check all connections for leaks.
Cylinder does not retract	<ul style="list-style-type: none"> • Required surfaces are not adequately lubricated with a high-pressure lubricant such as STP®. • Valve on hydraulic pump has not been released to allow hydraulic fluid to flow to the pump.
Underset ferrule	<ul style="list-style-type: none"> • Too low of a presetting pressure was used. • Positive stop of tube nut to body die was not reached (Ferulok only). • Ferrule placed on the tube incorrectly. • No lubrication was used on the ferrule and body.
Overset ferrule	<ul style="list-style-type: none"> • Too high of a presetting.

Table 10 — Hyferset Machine and Components Troubleshooting Guide

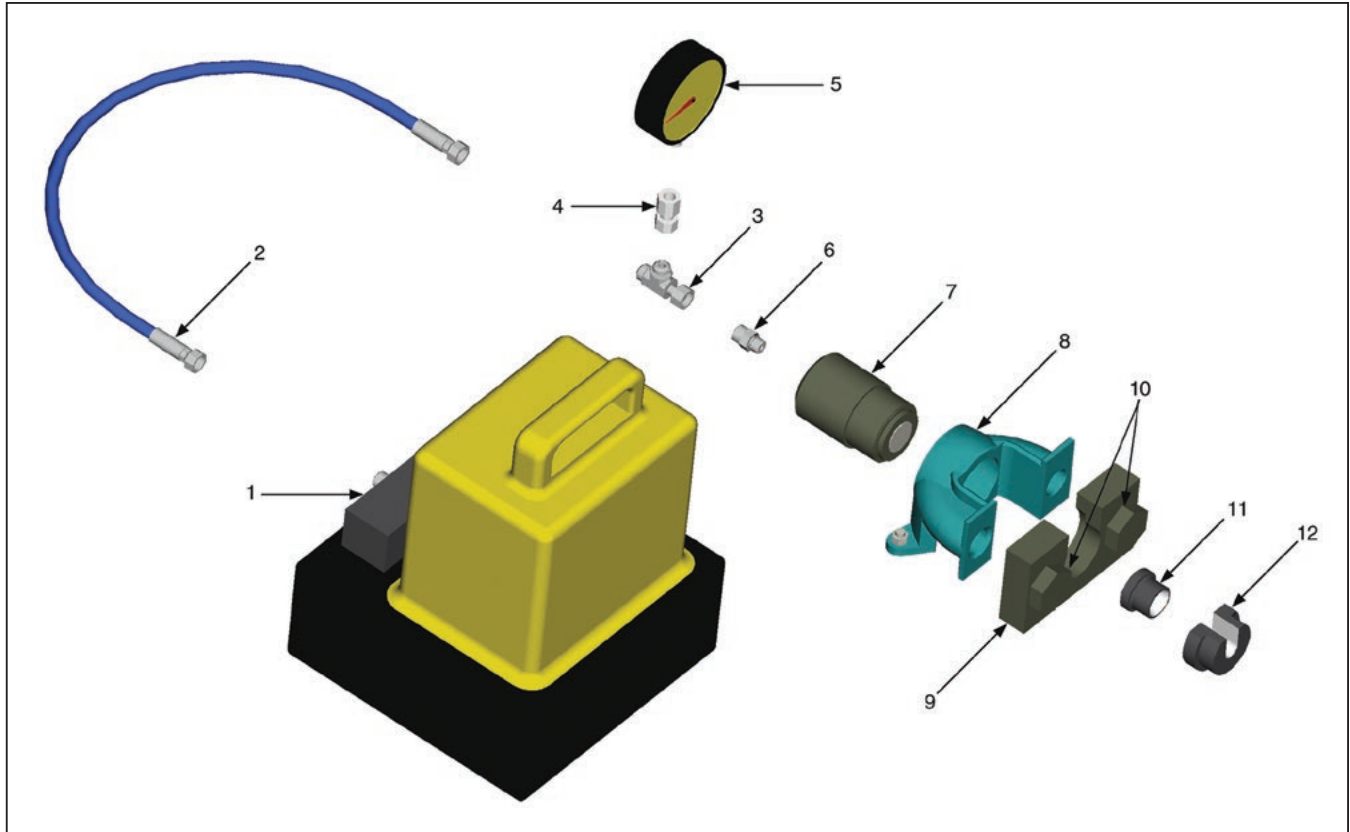

Fig. 25 — Hyferset Parts Schematic

Hyferset Parts Schematic

Item No.	Part Description	Part Number
–	Hyferset Basic Unit	611011A
–	Hyferset Kit: includes Basic Unit, hand hydraulic pump, one adapter, (6 FLO-S), wooden carrying case, operation manual and video.	611049C
1	Electric - Hydraulic Pump, 10,000 psi Hand - Hydraulic Pump, 10,000 psi	900085 900086
2	3' Hose Assembly, 10,000 psi	910004
3	"T" Adapter for Gauge	6 R6LO-S
4	Swivel Adapter for Gauge	6 G6L-S
5	Pressure Gauge	900044
6	Male Connector	6 FLO-S
7	Cylinder Assembly	611023
8	Body (Hyferset Casting)	690078
9	Back-up Plate	680369
10	Bolts (2 required for unit)	680368
11	Body Die for EO/EO-2 Body Die for Ferulok	See page 4 See page 8
12	Nut Support for EO/EO-2	See page 4

Table 11 — Hyferset Machine and Components Parts Schematic

PARKER-HANNIFIN CORPORATION
OFFER OF SALE

The goods, services or work (referred to as the "Products") offered by Parker-Hannifin Corporation, its subsidiaries, groups, divisions, and authorized distributors ("Seller") are offered for sale at prices indicated in the offer, or as may be established by Seller. The offer to sell the Products and acceptance of Seller's offer by any customer ("Buyer") is contingent upon, and will be governed by all of the terms and conditions contained in this Offer of Sale. Buyer's order for any Products specified in Buyer's purchase document or Seller's offer, proposal or quote ("Quote") attached to the purchase order, when communicated to Seller verbally, or in writing, shall constitute acceptance of this offer.

1. Terms and Conditions. Seller's willingness to offer Products for sale or accept an order for Products is subject to the terms and conditions contained in this Offer of Sale or any newer version of the same, published by Seller electronically at www.parker.com/saleterms/. Seller objects to any contrary or additional terms or conditions of Buyer's order or any other document or other communication issued by Buyer.

2. Price; Payment. Prices stated on Seller's Quote are valid for thirty (30) days, except as explicitly otherwise stated therein, and do not include any sales, use, or other taxes or duties unless specifically stated. Seller reserves the right to modify prices to adjust for any raw material price fluctuations. Unless otherwise specified by Seller, all prices are F.C.A. Seller's facility (INCOTERMS 2010). Payment is subject to credit approval and payment for all purchases is due thirty (30) days from the date of invoice (or such date as may be specified by Seller's Credit Department). Unpaid invoices beyond the specified payment date incur interest at the rate of 1.5% per month or the maximum allowable rate under applicable law.

3. Shipment; Delivery; Title and Risk of Loss. All delivery dates are approximate. Seller is not responsible for damages resulting from any delay. Regardless of the manner of shipment, delivery occurs and title and risk of loss or damage pass to Buyer, upon placement of the Products with the shipment carrier at Seller's facility. Unless otherwise stated, Seller may exercise its judgment in choosing the carrier and means of delivery. No deferral of shipment at Buyer's request beyond the respective dates indicated will be made except on terms that will indemnify, defend and hold Seller harmless against all loss and additional expense. Buyer shall be responsible for any additional shipping charges incurred by Seller due to Buyer's acts or omissions.

4. Warranty. Seller warrants that the Products sold hereunder shall be free from defects in material or workmanship for a period of twelve (12) months from the date of delivery or 2,000 hours of normal use, whichever occurs first. All prices are based upon the exclusive limited warranty stated above, and upon the following disclaimer: **DISCLAIMER OF WARRANTY: THIS WARRANTY IS THE SOLE AND ENTIRE WARRANTY PERTAINING TO PRODUCTS PROVIDED. SELLER DISCLAIMS ALL OTHER WARRANTIES, EXPRESS AND IMPLIED, INCLUDING DESIGN, MERCHANTABILITY AND FITNESS FOR A PARTICULAR PURPOSE.**

5. Claims; Commencement of Actions. Buyer shall promptly inspect all Products upon receipt. No claims for shortages will be allowed unless reported to the Seller within ten (10) days of delivery. No other claims against Seller will be allowed unless asserted in writing within thirty (30) days after delivery. Buyer shall notify Seller of any alleged breach of warranty within thirty (30) days after the date the defect is or should have been discovered by Buyer. Any claim or action against Seller based upon breach of contract or any other theory, including tort, negligence, or otherwise must be commenced within twelve (12) months from the date of the alleged breach or other alleged event, without regard to the date of discovery.

6. LIMITATION OF LIABILITY. IN THE EVENT OF A BREACH OF WARRANTY, SELLER WILL, AT ITS OPTION, REPAIR OR REPLACE A DEFECTIVE PRODUCT, OR REFUND THE PURCHASE PRICE WITHIN A REASONABLE PERIOD OF TIME. **IN NO EVENT IS SELLER LIABLE FOR ANY SPECIAL, INDIRECT, INCIDENTAL OR CONSEQUENTIAL DAMAGES ARISING OUT OF, OR AS THE RESULT OF, THE SALE, DELIVERY, NON-DELIVERY, SERVICING, USE OR LOSS OF USE OF THE PRODUCTS OR ANY PART THEREOF, OR FOR ANY CHARGES OR EXPENSES OF ANY NATURE INCURRED WITHOUT SELLER'S WRITTEN CONSENT, WHETHER BASED IN CONTRACT, TORT OR OTHER LEGAL THEORY. IN NO EVENT SHALL SELLER'S LIABILITY UNDER ANY CLAIM MADE BY BUYER EXCEED THE PURCHASE PRICE OF THE PRODUCTS.**

7. User Responsibility. The user, through its own analysis and testing, is solely responsible for making the final selection of the system and Product and assuring that all performance, endurance, maintenance, safety and warning requirements of the application are met. The user must analyze all aspects of the application and follow applicable industry standards and Product information. If Seller provides Product or system options based upon data or specifications provided by the user, the user is responsible for determining that such data and specifications are suitable and sufficient for all applications and reasonably foreseeable uses of the Products or systems.

8. Loss to Buyer's Property. Any designs, tools, patterns, materials, drawings, confidential information or equipment furnished by Buyer or any other items which become Buyer's property, will be considered obsolete and may be destroyed by Seller after two (2) consecutive years have elapsed without Buyer ordering the items manufactured using such property. Seller shall not be responsible for any loss or damage to such property while it is in Seller's possession or control.

9. Special Tooling. A tooling charge may be imposed for any special tooling, including without limitation, dies, fixtures, molds and patterns, acquired to manufacture Products. Such special tooling shall be and remain Seller's property notwithstanding payment of any charges by Buyer. In no event will Buyer acquire any interest in apparatus belonging to Seller which is utilized in the manufacture of the Products, even if such apparatus has been specially converted or adapted for such manufacture and notwithstanding any charges paid by Buyer. Unless otherwise agreed, Seller has the right to alter, discard or otherwise dispose of any special tooling or other property in its sole discretion at any time.

10. Buyer's Obligation; Rights of Seller. To secure payment of all sums due or otherwise, Seller retains a security interest in all Products delivered to Buyer and this agreement is deemed to be a Security Agreement under the Uniform Commercial Code. Buyer authorizes Seller as its attorney to execute and file on Buyer's behalf all documents Seller deems necessary to perfect its security interest.

11. Improper Use and Indemnity. Buyer shall indemnify, defend, and hold Seller harmless from any losses, claims, liabilities, damages, lawsuits, judgments and costs (including attorney

fees and defense costs), whether for personal injury, property damage, patent, trademark or copyright infringement or any other claim, brought by or incurred by Buyer, Buyer's employees, or any other person, arising out of: (a) improper selection, application, design, specification or other misuse of Products purchased by Buyer from Seller; (b) any act or omission, negligent or otherwise, of Buyer; (c) Seller's use of patterns, plans, drawings, or specifications furnished by Buyer to manufacture Products; or (d) Buyer's failure to comply with these terms and conditions. Seller shall not indemnify Buyer under any circumstance except as otherwise provided.

12. Cancellations and Changes. Buyer may not cancel or modify or cancel any order for any reason, except with Seller's written consent and upon terms that will indemnify, defend and hold Seller harmless against all direct, incidental and consequential loss or damage. Seller may change Product features, specifications, designs and availability.

13. Limitation on Assignment. Buyer may not assign its rights or obligations under this agreement without the prior written consent of Seller.

14. Force Majeure. Seller does not assume the risk and is not liable for delay or failure to perform any of Seller's obligations by reason of events or circumstances beyond its reasonable control (hereinafter "Events of Force Majeure"). Events of Force Majeure shall include without limitation: accidents, strikes or labor disputes, acts of any government or government agency, acts of nature, delays or failures in delivery from carriers or suppliers, shortages of materials, or any other cause beyond Seller's reasonable control.

15. Waiver and Severability. Failure to enforce any provision of this agreement will not invalidate that provision; nor will any such failure prejudice Seller's right to enforce that provision in the future. Invalidation of any provision of this agreement by legislation or other rule of law shall not invalidate any other provision herein. The remaining provisions of this agreement will remain in full force and effect.

16. Termination. Seller may terminate this agreement for any reason and at any time by giving Buyer thirty (30) days prior written notice. Seller may immediately terminate this agreement, in writing, if Buyer: (a) breaches any provision of this agreement (b) appoints a trustee, receiver or custodian for all or any part of Buyer's property (c) files a petition for relief in bankruptcy on its own behalf, or one or more filed by a third party (d) makes an assignment for the benefit of creditors; or (e) dissolves its business or liquidates all or a majority of its assets.

17. Governing Law. This agreement and the sale and delivery of all Products are deemed to have taken place in, and shall be governed and construed in accordance with, the laws of the State of Ohio, as applicable to contracts executed and wholly performed therein and without regard to conflicts of laws principles. Buyer irrevocably agrees and consents to the exclusive jurisdiction and venue of the courts of Cuyahoga County, Ohio with respect to any dispute, controversy or claim arising out of or relating to this agreement.

18. Indemnity for Infringement of Intellectual Property Rights. Seller is not liable for infringement of any patents, trademarks, copyrights, trade dress, trade secrets or similar rights except as provided in this Section. Seller will defend and indemnify Buyer against allegations of infringement of U.S. patents, U.S. trademarks, copyrights, trade dress and trade secrets ("Intellectual Property Rights"). Seller will defend at its expense and will pay the cost of any settlement or damages awarded in an action brought against Buyer based on an allegation that a Product sold pursuant to this agreement infringes the Intellectual Property Rights of a third party. Seller's obligation to defend and indemnify Buyer is contingent on Buyer notifying Seller within ten (10) days after Buyer becomes aware of such allegations of infringement, and Seller having sole control over the defense of any allegations or actions including all negotiations for settlement or compromise. If a Product is subject to a claim that it infringes the Intellectual Property Rights of a third party, Seller may, at its sole expense and option, procure for Buyer the right to continue using the Product, replace or modify the Product so as to make it noninfringing, or offer to accept return of the Product and refund the purchase price less a reasonable allowance for depreciation. Notwithstanding the foregoing, Seller is not liable for claims of infringement based on information provided by Buyer, or directed to Products delivered hereunder for which the designs are specified in whole or part by Buyer, or infringements resulting from the modification, combination or use in a system of any Product sold hereunder. The foregoing provisions of this Section constitute Seller's sole and exclusive liability and Buyer's sole and exclusive remedy for infringement of Intellectual Property Rights.

19. Entire Agreement. This agreement contains the entire agreement between the Buyer and Seller and constitutes the final, complete and exclusive expression of the terms of sale. All prior or contemporaneous written or oral agreements or negotiations with respect to the subject matter are herein merged. The terms contained herein may not be modified unless in writing and signed by an authorized representative of Seller.

20. Compliance with Laws. Buyer agrees to comply with all applicable laws, regulations, and industry and professional standards of care, including those of the United Kingdom, the United States of America, and the country or countries in which Buyer may operate, including without limitation the U. K. Bribery Act, the U.S. Foreign Corrupt Practices Act ("FCPA"), the U.S. Anti-Kickback Act ("Anti-Kickback Act") and the U.S. Food Drug and Cosmetic Act ("FDCA"), each as currently amended, and the rules and regulations promulgated by the U.S. Food and Drug Administration ("FDA"), and agrees to indemnify and hold harmless Seller from the consequences of any violation of such provisions by Buyer, its employees or agents. Buyer acknowledges that it is familiar with the provisions of the U. K. Bribery Act, the FCPA, the FDA, and the Anti-Kickback Act, and certifies that Buyer will adhere to the requirements thereof. In particular, Buyer represents and agrees that Buyer will not make any payment or give anything of value, directly or indirectly to any governmental official, any foreign political party or official thereof, any candidate for foreign political office, or any commercial entity or person, for the purpose of influencing such person to purchase Products or otherwise benefit the business of Seller.

05/14



Parker Fluid Connectors Group

North American Divisions & Distribution Service Centers

Your complete source for quality tube fittings, hose & hose fittings, brass & composite fittings, quick-disconnect couplings, valves and assembly tools, locally available from a worldwide network of authorized distributors.

Fittings:

Available in inch and metric sizes covering SAE, BSP, DIN, GAZ, JIS and ISO thread configurations, manufactured from steel, stainless steel, brass, aluminum, nylon and thermoplastic.

Hose, Tubing and Bundles:

Available in a wide variety of sizes and materials including rubber, wire-reinforced, thermoplastic, hybrid and custom compounds.

Worldwide Availability:

Parker operates Fluid Connectors manufacturing locations and sales offices throughout North America, South America, Europe and Asia-Pacific.

For information, call toll free...

**1-800-C-PARKER
(1-800-272-7537)**

North American Divisions

Fluid System Connectors Division

Otsego, MI
phone 269 694 9411
fax 269 694 4614

Hose Products Division

Wickliffe, OH
phone 440 943 5700
fax 440 943 3129

Industrial Hose Division

Wickliffe, OH
phone 440 883 2120
fax 440 833 2230

Parflex Division

Ravenna, OH
phone 330 296 2871
fax 330 296 8433

Quick Coupling Division

Minneapolis, MN
phone 763 544 7781
fax 763 544 3418

Tube Fittings Division

Columbus, OH
phone 614 279 7070
fax 614 279 7685

Distribution Service Centers

Buena Park, CA

phone 714 522 8840
fax 714 994 1183

Conyers, GA

phone 770 929 0330
fax 770 929 0230

Louisville, KY

phone 502 937 1322
fax 502 937 4180

Portland, OR

phone 503 283 1020
fax 503 283 2201

Toledo, OH

phone 419 878 7000
fax 419 878 7001
fax 419 878 7420
(FCG Kit Operations)

Canada

Grimsby, ONT

phone 905 945 2274
fax 905 945 3945
(Contact Grimsby for other Service Center locations.)

Mexico

Toluca, MEX

phone (52) 722 2754 200
fax (52) 722 2722 168



Parker Hannifin Corporation

Tube Fittings Division

3885 Gateway Blvd.
Columbus, OH 43228
phone 614 279 7070
fax 614 279 7685
www.parker.com/tfd